

### S Type

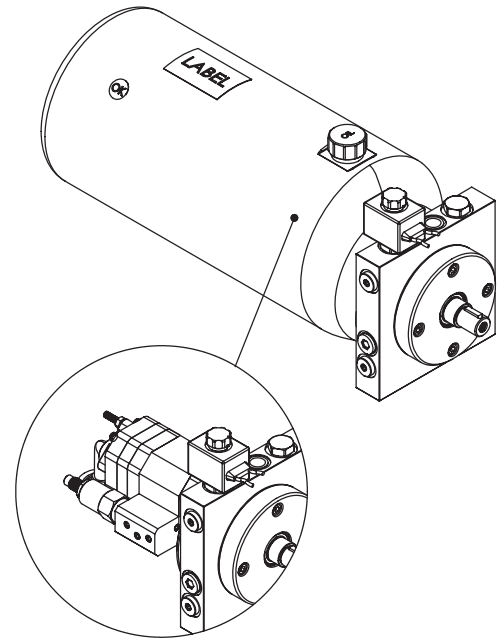

### A Type + Cetop 03

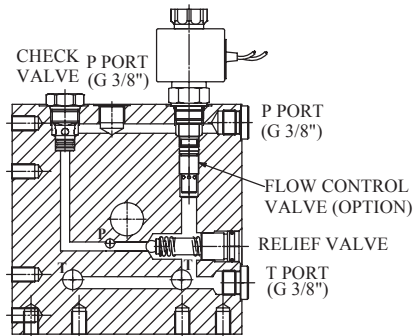
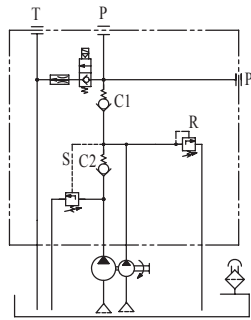
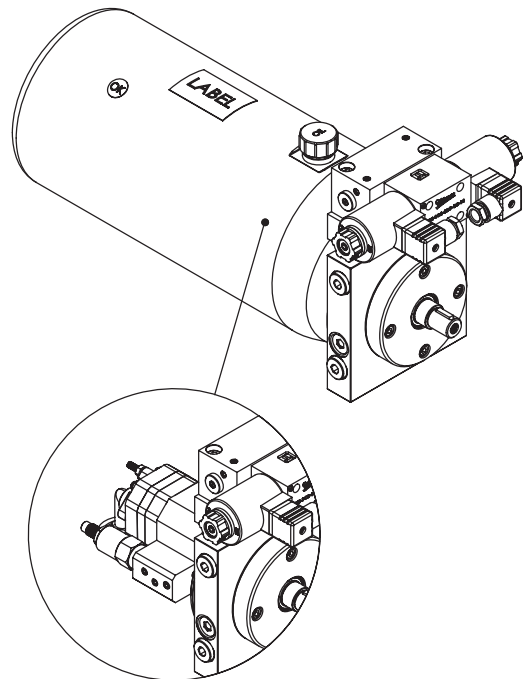
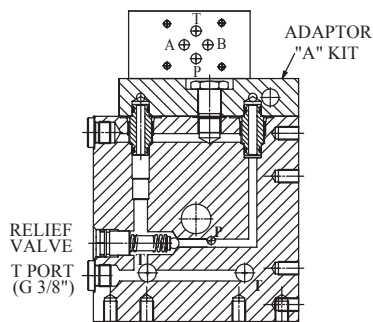
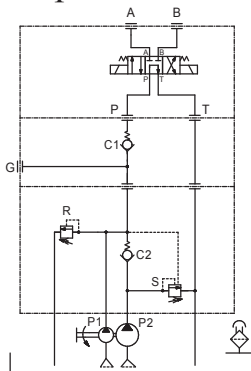

The W84BT series power pack is designed for applications that need high pressure and larger flow, but use a customer supplied low-power transmission. Because the power pack uses a standard manifold (W800532), they will have the same functions as the W80BT series power pack.

- ◆ Pump capacity range is from 0.5cc/rev to 7.3cc/rev.
  - ◆ Standard tank sizes vary from 2.4L to 8.0L. Tailor made tanks are also available.
  - ◆ Hydraulic circuit valves can be inter-changed with the standard manifold.
- Custom made circuits are also available.

Before the power packs leave our factory they are fully inspected and tested by our QA/QC (ISO 9001) team. If you have any questions or need a custom design, please feel free to contact us.

NOTE : The low-pressure relief valve must be pre-set before installing the tank.